



**American Water Works  
Association**

*Dedicated to the World's Most Important Resource™*

**ANSI/AWWA C651-14**  
(Revision of ANSI/AWWA C651-05)

**AWWA Standard**

# Disinfecting Water Mains

Effective date: Feb. 1, 2015.  
First edition approved by AWWA Board of Directors Sept. 30, 1947.  
This edition approved June 8, 2014.  
Approved by American National Standards Institute Nov. 18, 2014.



## AWWA Standard

This document is an American Water Works Association (AWWA) standard. It is not a specification. AWWA standards describe minimum requirements and do not contain all of the engineering and administrative information normally contained in specifications. The AWWA standards usually contain options that must be evaluated by the user of the standard. Until each optional feature is specified by the user, the product or service is not fully defined. AWWA publication of a standard does not constitute endorsement of any product or product type, nor does AWWA test, certify, or approve any product. The use of AWWA standards is entirely voluntary. This standard does not supersede or take precedence over or displace any applicable law, regulation, or codes of any governmental authority. AWWA standards are intended to represent a consensus of the water supply industry that the product described will provide satisfactory service. When AWWA revises or withdraws this standard, an official notice of action will be placed in the Official Notice section of *Journal - American Water Works Association*. The action becomes effective on the first day of the month following the month of *Journal - American Water Works Association* publication of the official notice.

## American National Standard

An American National Standard implies a consensus of those substantially concerned with its scope and provisions. An American National Standard is intended as a guide to aid the manufacturer, the consumer, and the general public. The existence of an American National Standard does not in any respect preclude anyone, whether that person has approved the standard or not, from manufacturing, marketing, purchasing, or using products, processes, or procedures not conforming to the standard. American National Standards are subject to periodic review, and users are cautioned to obtain the latest editions. Producers of goods made in conformity with an American National Standard are encouraged to state on their own responsibility in advertising and promotional materials or on tags or labels that the goods are produced in conformity with particular American National Standards.

CAUTION NOTICE: The American National Standards Institute (ANSI) approval date on the front cover of this standard indicates completion of the ANSI approval process. This American National Standard may be revised or withdrawn at any time. ANSI procedures require that action be taken to reaffirm, revise, or withdraw this standard no later than five years from the date of ANSI approval. Purchasers of American National Standards may receive current information on all standards by calling or writing the American National Standards Institute, 25 West 43rd Street, Fourth Floor, New York, NY 10036; 212.642.4900, or emailing [info@ansi.org](mailto:info@ansi.org).

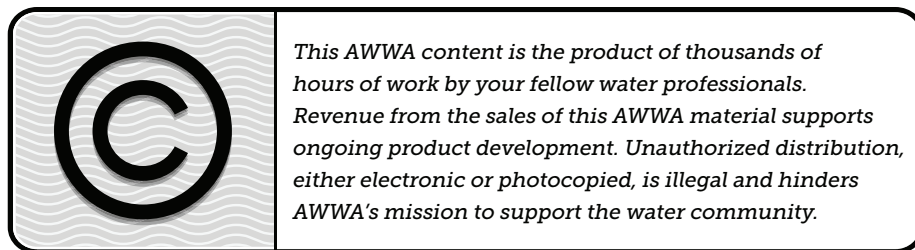

ISBN-13, print: 978-1-62576-046-3

eISBN-13, electronic: 978-1-61300-310-7

DOI: <http://dx.doi.org/10.12999/AWWA.C651.14>

---

All rights reserved. No part of this publication may be reproduced or transmitted in any form or by any means, electronic or mechanical, including photocopy, recording, or any information or retrieval system, except in the form of brief excerpts or quotations for review purposes, without the written permission of the publisher.

Copyright © 2015 by American Water Works Association  
Printed in USA

# Committee Personnel

The AWWA Standards Committee on Disinfection of Facilities, which reviewed and approved this standard, had the following personnel at the time of approval:

Betsy Reilley, *Chair*

## *General Interest Members*

G. Boyd,* Standards Council Liaison, Cadmus Group, Seattle, Wash.	(AWWA)
K.C. Choquette, Consultant, Des Moines, Iowa	(AWWA)
C.B. Hagar, Carollo Engineers, Phoenix, Ariz.	(AWWA)
J.M. Henderson, Consultant, Concord, Mass.	(AWWA)
P.J. Olson,* Standards Staff Liaison, AWWA, Denver, Colo.	(AWWA)
S. Vidika, Dixon Engineering Inc., Medina, Ohio	(AWWA)
J.S. Wailes, Consultant, Black Hawk, Colo.	(AWWA)
T.W. Walker, New York State Department of Health, Victor, N.Y.	(AWWA)
M.L. Wentink, Nebraska DHHS Division of Public Health, North Platte, Neb.	(AWWA)

## *Producer Members*

R.J. Gordhamer, Measurement Technologies Inc., Redmond, Wash.	(AWWA)
D.T. Hanson, Design Water Technologies, Shorewood, Minn.	(AWWA)
P.L. Smith, Smith LaSalle Inc., Western Springs, Ill.	(AWWA)

## *User Members*

G.A. Burlingame, Philadelphia Water Department, Philadelphia, Penn.	(AWWA)
R.C. Lorenz, Westerville Water Plant, Westerville, Ohio	(AWWA)
P.M. Marchand, Bristol County Water Authority, Warren, R.I.	(AWWA)
B. Reilley, MWRA, Southborough, Mass.	(AWWA)
E.D. Schwartz, New Jersey American Water Company, Plainsboro, N.J.	(AWWA)
B.L. Whitteberry, Greater Cincinnati Water Works, Cincinnati, Ohio	(AWWA)

---

\* Liaison, nonvoting

This page intentionally blank.

# Contents

*All AWWA standards follow the general format indicated subsequently. Some variations from this format may be found in a particular standard.*

SEC.	PAGE	SEC.	PAGE
<b>Foreword</b>		4.4	Continuous-Feed Method of Chlorination..... 6
I	Introduction..... vii	4.5	Slug Method of Chlorination ..... 10
I.A	Background..... vii	4.6	Spray Disinfection for Large Transmission Lines..... 11
I.B	History..... vii	4.7	Basic Disinfection Procedure for New Mains ..... 11
I.C	Acceptance..... vii	4.8	Preventive and Corrective Measures During New Construction ..... 12
II	Special Issues..... viii	4.9	Final Flushing for New Mains..... 14
II.A	Information on Application of This Standard..... viii	4.10	Final Connections to Existing Mains..... 14
III	Use of This Standard ..... xi	4.11	Disinfection Procedures When Cutting Into or Repairing Existing Pipe ..... 15
III.A	Purchaser Options and Alternatives ..... xi	<b>5</b>	<b>Verification</b>
III.B	Modification to Standard ..... xii	5.1	Bacteriological Tests ..... 19
IV	Major Revisions..... xii	5.2	Optional Sampling and Testing..... 21
V	Comments ..... xiii	<b>6</b>	<b>Delivery</b> ..... 21
<b>Standard</b>		<b>Appendixes</b>	
<b>1</b>	<b>General</b>	A	Chlorine Residual Testing ..... 23
1.1	Scope ..... 1	A.1	DPD Drop Dilution Method (for Field Test) ..... 23
1.2	Purpose ..... 1	A.2	High-Range Chlorine Test Kits..... 24
1.3	Application..... 1	B	Chlorine Dosages ..... 25
<b>2</b>	<b>References</b> ..... 2	<b>Figures</b>	
<b>3</b>	<b>Definitions</b> ..... 2	1	Suggested Temporary Flushing/Testing Connection ..... 7
<b>4</b>	<b>Requirements</b>		
4.1	Forms of Chlorine for Disinfection ... 3		
4.2	General Considerations for All Methods of Chlorination..... 4		
4.3	Tablet/Granule Method of Chlorination..... 5		

SEC.	PAGE	SEC.	PAGE
2	9	4	9
Suggested Combination Blowoff and Sampling Tap .....		Chlorine Required to Produce an Initial 25-mg/L Concentration in 100 ft (30.5 m) of Pipe by Diameter .....	
<b>Tables</b>			
1	5	B.1	25
Weight of Calcium Hypochlorite Granules to Be Placed at Beginning of Main and at Each 500-ft (150-m) Interval .....		Amounts of Chemicals Required to Produce Various Chlorine Concentrations in 100,000 gal (378.5 m <sup>3</sup> ) of Water.....	
2	6	B.2	25
Number of 5-g Calcium Hypochlorite Tablets Required for Dose of 25 mg/L .....		Amounts of Chemicals Required to Produce Chlorine Concentrations of 200 mL in Various Volumes of Water .....	
3	7		
Required Flow and Openings (Either Taps or Hydrants) to Flush Pipelines at 3.0 ft/sec (0.91 m/sec) (40 psi [276 kPa] Residual Pressure in Water Main) .....			

---

# Foreword

*This foreword is for information only and is not a part of ANSI/AWWA C651.*

## **I. Introduction.**

I.A. *Background.* This standard describes methods of disinfecting newly constructed potable water mains; mains that have been removed from service for planned repairs or for maintenance that exposes them to contamination; mains that have undergone emergency repairs because of physical failure; and mains that, under normal operation, continue to show the presence of coliform organisms. The disinfecting agents discussed in this standard are chlorine solutions that may be derived from liquid chlorine ( $\text{Cl}_2$ ), calcium hypochlorite ( $\text{Ca}(\text{OCl})_2$ ), or sodium hypochlorite ( $\text{NaOCl}$ ). Combinations of free chlorine residual and contact time are provided. Chlorine dosage reference tables are provided as appendix B of this standard.

I.B. *History.* This standard was first approved on Sept. 30, 1947, by the AWWA Board of Directors and published as 7D.2-1948, A Procedure for Disinfecting Water Mains. Revisions were approved on Sept. 14, 1948; Mar. 6, 1953; May 27, 1954; June 2, 1968; and June 7, 1981. All were done under the designation ANSI/AWWA C601, Standard for Disinfecting Water Mains. In 1986, the designation of the standard was changed to ANSI/AWWA C651, and the subsequent editions were approved on Jan. 26, 1986; June 18, 1992; June 20, 1999; and Jan. 16, 2005. This edition was approved on June 8, 2014.

I.C. *Acceptance.* In May 1985, the US Environmental Protection Agency (USEPA) entered into a cooperative agreement with a consortium led by NSF International (NSF) to develop voluntary third-party consensus standards and a certification program for direct and indirect drinking water additives. Other members of the original consortium included the Water Research Foundation (formerly AwwaRF) and the Conference of State Health and Environmental Managers (COSHEM). The American Water Works Association (AWWA) and the Association of State Drinking Water Administrators (ASDWA) joined later.

In the United States, authority to regulate products for use in, or in contact with, drinking water rests with individual states.<sup>†</sup> Local agencies may choose to impose requirements more stringent than those required by the state. To evaluate the health

---

\* American National Standards Institute, 25 West 43rd Street, Fourth Floor, New York, NY 10036.

† Persons outside the United States should contact the appropriate authority having jurisdiction.

effects of products and drinking water additives from such products, state and local agencies may use various references, including

1. An advisory program formerly administered by USEPA, Office of Drinking Water, discontinued on Apr. 7, 1990.
2. Specific policies of the state or local agency.
3. Two standards developed under the direction of NSF\*: NSF/ANSI 60, Drinking Water Treatment Chemicals—Health Effects, and NSF/ANSI 61, Drinking Water System Components—Health Effects.
4. Other references, including AWWA standards, *Food Chemicals Codex*, *Water Chemicals Codex*,<sup>†</sup> and other standards considered appropriate by the state or local agency.

Various certification organizations may be involved in certifying products in accordance with NSF/ANSI 60. Individual states or local agencies have authority to accept or accredit certification organizations within their jurisdictions. Accreditation of certification organizations may vary from jurisdiction to jurisdiction.

Annex A, “Toxicology Review and Evaluation Procedures,” to NSF/ANSI 60 does not stipulate a maximum allowable level (MAL) of a contaminant for substances not regulated by a USEPA final maximum contaminant level (MCL). The MALs of an unspecified list of “unregulated contaminants” are based on toxicity testing guidelines (noncarcinogens) and risk characterization methodology (carcinogens). Use of Annex A procedures may not always be identical, depending on the certifier.

ANSI/AWWA C651 does not address additives requirements. Thus, users of this standard should consult the appropriate state or local agency having jurisdiction in order to

1. Determine additives requirements including applicable standards.
2. Determine the status of certifications by parties offering to certify products for contact with, or treatment of, drinking water.
3. Determine current information on product certification.

## **II. Special Issues.**

II.A. *Information on Application of This Standard.* Generally, it is easier to disinfect a new main than one that has had emergency repairs in terms of access, sanitary control, and the time available for disinfection, sampling, and testing.

---

\* NSF International, 789 North Dixboro Road, Ann Arbor, MI 48105.

† Both publications available from National Academy of Sciences, 500 Fifth Street, NW, Washington, DC 20001.



For a new main, there is typically more time available for disinfection and testing since there is no immediate demand from customers. Given the often significant amount of time and materials involved in a new water main project, careful disinfection and testing of the main are reasonable and necessary to ensure public health protection.

Conditions for pipe repair projects vary tremendously in terms of the size of the repair, the sanitary conditions, and the time constraints resulting from immediate customer demands. It should be noted if the line is depressurized or opened to the environment prior to or during repair, the sanitary integrity of the pipe is compromised and it is critical to follow sanitary procedures throughout the repair—not just as it is being returned to service. Crews responsible for the repair of mains should be aware of the potential health hazards and be trained to carefully observe prescribed construction practices and disinfection procedures.

Because of the differences between initial installation and repair, the disinfection requirements for each situation are also different. The installation of new mains requires that two sets of samples for coliform analysis are collected at least 16 hr apart, or two sets collected 15 min apart after at least a 16-hr rest period. For repaired mains that are depressurized and/or wholly or partially dewatered, one set of samples may be required, and depending on the sanitary conditions, the line may be returned to service prior to the completion of bacteriological testing. For repaired mains that are maintained under pressurized conditions at all times, bacteriological testing is not required.

When required, samples are now specified to be collected at least 16 hr apart, or 15 min apart after a 16-hr rest period. The purpose of this change is to consider the balance between public health, improved test methods, and timely work completion. This timing is sufficient to allow bacterial regrowth within the line if there was a contamination problem and provides more flexibility in the scheduling of various work activities.

Bacteriological testing in accordance with Sec. 5.1 is used to verify the absence of coliform organisms and is generally accepted as verification that disinfection of the pipeline has been accomplished; and following sanitary practices for handling and installation of pipe, valves, fittings, and accessories, coupled with adequate flushing of the line before disinfection, is necessary to ensure the disinfected pipeline will be ready for connection to the water system. Failure to pass the bacteriological test requires that the flushing or disinfection process be repeated. It must be remembered that the final water quality test is not the primary means for certifying the sanitary condition of a main. The sanitary

handling of materials, the practices during construction, and the continual inspection of the work are the primary means for ensuring the sanitary condition of the water main.

Four methods of disinfecting newly constructed water mains are described in this standard: the tablet method, the continuous-feed method, the slug method, and the spray method. The utility should decide which of these methods is most suitable for a given situation. Factors to consider when choosing a method should include the length and diameter of the main, type of joints present, availability of materials, equipment required for disinfection, training of the personnel who will perform the disinfection, and safety concerns. For example, if gas chlorination is the chosen chemical when either continuous-feed or slug methods are being used, use only properly designed and constructed equipment; makeshift equipment is not acceptable when liquid chlorine (gas) cylinders are used.

Thorough consideration should be given to the impact of highly chlorinated water flushed into the environment. If there is any question that damage may be caused by chlorinated-waste discharge (to fish life, plant life, physical installations, or other downstream water uses of any type), then an adequate amount of reducing agent should be applied to water being disposed of in order to thoroughly neutralize the chlorine residual remaining in the water.

The tablet method cannot be used unless the main can be kept clean and dry. It cannot be used in large-diameter mains if it is necessary for a worker to enter the main to grout joints or perform inspection because the tablets may release toxic fumes after exposure to moist air. When using the tablet method, the chlorine concentration is not uniform throughout the main because the hypochlorite solution is dense and tends to concentrate at the bottom of the pipe. The use of the tablet method precludes preliminary flushing. The tablet method is convenient to use in mains having diameters up to 24 in. (600 mm), and it requires no special equipment.

The continuous-feed method is suitable for general application. Preliminary flushing removes light particulates from the main but not from the pipe-joint spaces. The chlorine concentration is uniform throughout the main.

The slug method is suitable for use in large-diameter mains where the volume of water makes the continuous-feed method impractical and difficult to achieve for short attachments. The slug method results in appreciable savings of chemicals used to disinfect long large-diameter mains. Also, this method reduces the volume of heavily chlorinated water to be flushed to waste.

The spray method is suitable for use in large-diameter transmission lines where spray equipment can be used to disinfect all surfaces of the pipe. This method reduces the volume of heavily chlorinated water to be flushed to waste.

The purpose of all four chlorination methods is to disinfect water lines, resulting in an absence of coliforms as confirmed by laboratory analysis. As noted above, the four methods attempt to provide flexibility in responding to specific situations. The tablet and continuous-feed methods both have initial chlorine concentrations of 25 mg/L and a minimum contact time of 24 hr. Because the tablet method cannot be flushed and cleaned prior to disinfection, the required free chlorine residual must be detectable ( $\geq 0.2$  mg/L) after 24 hr. Because the continuous-feed method can be used to flush particles, a higher free chlorine residual of 10 mg/L is required after 24 hr. To meet the needs of situations requiring reduced contact times, the slug method allows only a 3-hr contact time but requires a 100-mg/L initial chlorine dosage. For larger transmission lines, spray disinfection using 200 mg/L free chlorine may be a suitable option, minimizing discharges of highly chlorinated water. While the contact times of the methods may not be identical, the end result, absence of coliforms, is the same for all four methods.

Disinfectants other than chlorine may be appropriate to use. Although this standard describes only the use of liquid chlorine (gas), sodium hypochlorite solutions, and calcium hypochlorite, the applicability of other disinfectants should be evaluated. Ozone and chemical cleaners have been used, and these warrant further investigation. Whichever disinfectant or method is selected, approval from the local regulatory agency may be required.

**III. Use of This Standard.** It is the responsibility of the user of an AWWA standard to determine that the products described in that standard are suitable for use in the particular application being considered.

III.A. *Purchaser Options and Alternatives.* This standard is written as though the disinfection work will be performed by the purchaser's personnel. Where the work is to be performed using a separate contract or as part of a contract for installing mains,\* appropriate provisions should be included in the purchase documents to ensure that the constructor is specifically instructed as to its responsibilities. The following information should be provided by the purchaser.

---

\* Refer to other AWWA standards and manuals for design criteria and installation procedures for various pipe materials.

1. Standard used— that is, ANSI/AWWA C651, Standard for Disinfection of Water Mains, of latest revision.
2. Approval requirements before use.
3. Those procedures included in the standard that are designated as optional, that are to be included in the purchase documents.
4. Whether compliance with NSF/ANSI 60, Drinking Water Chemicals—Health Effects, is required.
5. Whether compliance with NSF/ANSI 61, Drinking Water System Components—Health Effects, is required.
6. Details of other federal, state or provincial, and local requirements (Section 4).
7. Form of chlorine to be used (Sec. 4.1.1, 4.1.2, and 4.1.3).
8. Method of chlorination (Sec. 4.3, 4.4, 4.5, and 4.6).
9. Flushing locations, rates of flushing, and locations of drainage facilities (Sec. 4.4.2, 4.9.1, and 4.9.2).
10. Responsibility for tapping existing mains and connections to new mains (Sec. 4.4.3[1], 4.4.3[2], and 4.10).
11. The number and frequency of samples for bacteriological tests (Sec. 5.1.1, 5.1.2, and 5.2).
12. Method of taking samples (Sec. 5.1.3).

III.B. *Modification to Standard.* Any modification of the provisions, definitions, or terminology in this standard must be provided by the purchaser.

**IV. Major Revisions.** Major revisions made to the standard in this edition include the following:

1. Clarified differences in the requirements between new and repaired mains (foreword II.A, Sec. 1.1, and 4.11).
2. Changed the requirement for bacteriological sampling in new mains from two sets of samples 24 hr apart to add two options for two sets of samples: Option A samples are 16 hr apart, and Option B samples are 15 min apart after a 16-hr rest period (foreword II.A and Sec. 5.1).
3. The flushing rate of 2.5 ft/sec has been increased to 3.0 ft/sec for a scour flush based on testing performed under Water Research Foundation Project No. 4307, which indicates the threshold velocity of 2.5 to 3.0 ft/sec for successful flushing (2.5- to 3.0-log removal) of sand particles. Since this is a threshold velocity, 3.0 ft/sec was chosen for the standard (Sec. 4.4.2 and Table 3).
4. Added spray disinfection method for large transmission mains (Sec. 4.6).

5. Appendix C has been deleted, and instead, a reference to ANSI/AWWA C655 is made for dechlorination (Sec. 4.7 and 4.9.2).

6. Developed a rationale for evaluating risk during pipe repairs and the level of disinfection and sampling needed under those conditions (Sec. 4.11).

**V. Comments.** If you have any comments or questions about this standard, please call the AWWA Engineering and Technical Services at 303.794.7711, FAX at 303.795.7603; write to the group at 6666 West Quincy Avenue, Denver, CO 80235-3098; or email the group at [standards@awwa.org](mailto:standards@awwa.org).

This page intentionally blank.



**American Water Works  
Association**

*Dedicated to the World's Most Important Resource™*

**ANSI/AWWA C651-14**  
(Revision of ANSI/AWWA C651-05)

**AWWA Standard**

---

# Disinfecting Water Mains

---

## SECTION 1: GENERAL

---

### **Sec. 1.1 Scope**

This standard describes essential procedures for the disinfection of new and repaired potable water mains. New water mains shall be disinfected before they are placed in service. Water mains taken out of service for inspection, repair, or other activities may or may not require disinfection and sampling, depending on the risk of contamination. This standard describes the process for evaluating the risk under different conditions.

### **Sec. 1.2 Purpose**

The purpose of this standard is to define the minimum requirements for the disinfection of water mains, including the preparation of water mains, application of chlorine, and sampling and testing for the presence of coliform bacteria.

### **Sec. 1.3 Application**

This standard can be referenced in the purchase documents for the disinfection of water mains and can be used as a guide for the preparation of water mains, application of chlorine, and sampling and testing for the presence of coliform bacteria. The stipulations of this standard apply when this document has been referenced and only to the disinfection of water mains.

---

## SECTION 2: REFERENCES

---

This standard references the following documents. In their latest editions, they form a part of this standard to the extent specified within the standard. In any case of conflict, the requirements of this standard shall prevail.

ANSI\*/AWWA B300—Hypochlorites.

ANSI/AWWA B301—Liquid Chlorine.

ANSI/AWWA C652—Disinfection of Water Storage Facilities.

ANSI/AWWA C655—Field Dechlorination.

APHA,<sup>†</sup> AWWA, and WEF.<sup>‡</sup> *Standard Methods for the Examination of Water and Wastewater.*

AWWA Manual M12, *Simplified Procedures for Water Examination.*

NSF/ANSI 61—Drinking Water System Components—Health Effects.

---

## SECTION 3: DEFINITIONS

---

The following definitions shall apply in this standard:

1. *Available chlorine:* A measure of the amount of chlorine in chlorinated lime, hypochlorite compounds, chloramines, and other materials that are used for disinfection compared with the amount in elemental (liquid or gaseous) chlorine.

2. *Chlorine, combined:* The amount of chlorine combined with ammonia (NH<sub>3</sub>) or other compounds in water.

3. *Chlorine, free:* Also called *free available chlorine*, the amount of chlorine available as dissolved gas (Cl<sub>2</sub>), hypochlorous acid (HOCl), and hypochlorite (OCl<sup>-</sup>) that is not combined with ammonia (NH<sub>3</sub>) or other compounds in water that is available for disinfection.

4. *Chlorine residual:* Concentration of chlorine species present in water after the oxidant demand has been satisfied.

5. *Chlorine, total:* A combination of free chlorine, combined chlorine, and organochlorine species.

6. *Constructor:* The party that provides the work and materials for placement or installation.

---

\* American National Standards Institute, 25 West 43rd Street, Fourth Floor, New York, NY 10036.

† American Public Health Association, 800 I Street NW, Washington, DC 20001.

‡ Water Environment Federation, 601 Wythe Street, Alexandria, VA 22314.



7. *Liquid chlorine (gas)*: the commercially available form of liquefied elemental chlorine gas. (The term *liquid chlorine* is sometimes used to describe a hypochlorite solution. This use of the term is discouraged. See ANSI/AWWA B300, Hypochlorites.)

8. *Manufacturer*: The party that manufactures, fabricates, or produces materials or products.

9. *Purchaser*: The person, company, or organization that purchases any materials or work to be performed.

10. *Supplier*: The party that supplies material or services. A supplier may or may not be the manufacturer.

11. *Organochlorine*: Any organic compound containing chlorine as a constituent. Organochlorine compounds can form when chlorine reacts with organic substances.

---

## SECTION 4: REQUIREMENTS

---

Materials shall comply with the requirements of the Safe Drinking Water Act and other federal regulations for potable water, wastewater, and reclaimed water systems as applicable.

### Sec. 4.1 Forms of Chlorine for Disinfection

The forms of chlorine that may be used in the water main disinfection operations are liquid chlorine (gas), sodium hypochlorite solution, and calcium hypochlorite granules or tablets.

4.1.1 *Liquid chlorine (gas)*. Liquid chlorine (gas) conforming to ANSI/AWWA B301 contains 100 percent available chlorine and is packaged in steel containers usually of 100-lb, 150-lb, or 1-ton (45.4-kg, 68.0-kg, or 907.2-kg) net chlorine weight. Liquid chlorine (gas) shall be used only (1) in combination with appropriate gas-flow chlorinators and ejectors to provide a controlled high-concentration solution feed to the water to be chlorinated; (2) under the direct supervision of someone familiar with the biological, chemical, and physical properties of liquid chlorine (gas) and who is trained and equipped to handle any emergency that may arise; and (3) when appropriate safety practices are observed to protect working personnel and the public. Makeshift equipment is not acceptable when liquid chlorine (gas) cylinders are used.

4.1.2 *Sodium hypochlorite.* Sodium hypochlorite conforming to ANSI/AWWA B300 is available in liquid form in glass, rubber-lined, or plastic containers typically ranging in size from 1 qt (0.95 L) to 5 gal (18.92 L). Containers of 30 gal (113.6 L) or larger may be available in some areas. Sodium hypochlorite contains approximately 5 percent to 15 percent available chlorine, and the storage conditions and time must be controlled to minimize its deterioration. (Available chlorine is expressed as a percent of weight when the concentration is 5 percent or less, and usually as a percent of volume for higher concentrations. Percent  $\times$  10 = grams of available chlorine per liter of hypochlorite.)

4.1.3 *Calcium hypochlorite.* Calcium hypochlorite conforming to ANSI/AWWA B300 is available in granular form or in 5-g tablets and must contain approximately 65 percent available chlorine by weight. The material should be stored in a cool, dry, and dark environment to minimize its deterioration.

CAUTION: Tablets dissolve in approximately 7 hr and must be given adequate contact time. Do not use calcium hypochlorite intended for swimming pool disinfection, as this material has been sequestered and is extremely difficult to eliminate from the pipe after the desired contact time has been achieved.

## Sec. 4.2 General Considerations for All Methods of Chlorination

4.2.1 *General.* Four methods of chlorination are explained in this section: tablet, continuous feed, slug, and spray. The tablet method gives an initial chlorine dose of 25 mg/L; the continuous-feed method gives a 24-hr chlorine residual of not less than 10 mg/L; the slug method gives a 3-hr exposure of not less than 50 mg/L free chlorine; and the spray method gives a 30-min exposure of not less than 200 mg/L free chlorine. Caution should be used with highly chlorinated water when conducting hydrostatic pressure testing and with high-volume flushing of water.

4.2.2 *Flushing.* Potable water shall be used for disinfection, hydrostatic pressure testing, and flushing. Drainage should take place away from the construction or work area. Adequate drainage must be provided during flushing. If applicable, the valve(s) isolating the main from existing system should be locked out and tagged out to prevent unintentional release of the elevated chlorine residual water used for disinfection.

4.2.3 *Dechlorination.* When dechlorination is required, it is recommended that any high-velocity flushing be completed prior to disinfection. Dechlorination equipment may not be capable of handling high flows with high levels of chlorine.

**Table 1 Weight of calcium hypochlorite granules to be placed at beginning of main and at each 500-ft (150-m) interval**

Pipe Diameter ( $d$ )		Calcium Hypochlorite Granules	
<i>in.</i>	<i>(mm)</i>	<i>oz</i>	<i>(g)</i>
4	(100)	1.7	(48)
6	(150)	3.8	(108)
8	(200)	6.7	(190)
10	(250)	10.5	(298)
12	(300)	15.1	(428)
14 and larger	(350 and larger)	$D^2 \times 15.1$	$D^2 \times 428$

Where  $D$  is the inside pipe diameter, in feet  $D = d/12$

### Sec. 4.3 Tablet/Granule Method of Chlorination

4.3.1 *Tablet method.* The tablet method consists of placing calcium hypochlorite granules or tablets in the water main during installation and then filling the main with potable water to create a chlorine solution. This method may be used only if the pipes and appurtenances are kept clean and dry during construction.

WARNING: This procedure must not be used on solvent-welded plastic or on screwed-joint steel pipe because of the danger of fire or explosion from the reaction of the joint compounds with the calcium hypochlorite.

4.3.2 *Placement of calcium hypochlorite granules during construction.* Calcium hypochlorite granules shall be placed at the upstream end of the first section of pipe, at the upstream end of each branch main, and at 500-ft (150-m) intervals. The quantity of granules at each location shall be as shown in Table 1.

4.3.3 *Placement of calcium hypochlorite tablets during construction.* Calcium hypochlorite tablets (5-grams) shall be placed in the upstream end of each section of pipe to be disinfected, including branch lines. Also, at least one tablet shall be placed in each hydrant branch and in other appurtenances. The number of 5-g tablets required for each pipe section shall be  $0.0012 d^2 L$  rounded to the next higher integer, where  $d$  is the inside pipe diameter, in inches, and  $L$  is the length of the pipe section, in feet. Table 2 shows the number of tablets required for commonly used sizes of pipe. Calcium hypochlorite tablets shall be attached by an adhesive meeting the requirements of NSF/ANSI 61. There shall be adhesive only on the broadside of the tablet attached to the surface of the pipe. Attach tablets inside and at the top of the main. If the tablets are attached before the pipe section is placed in

**Table 2** Number of 5-g calcium hypochlorite tablets required for dose of 25 mg/L\*

Pipe Diameter		Length of Pipe Section, <i>ft (m)</i>				
		13 (4.0) or less	18 (5.5)	20 (6.1)	30 (9.1)	40 (12.2)
<i>in.</i>	<i>(mm)</i>	Number of 5-g Calcium Hypochlorite Tablets				
4	(100)	1	1	1	1	1
6	(150)	1	1	1	2	2
8	(200)	1	2	2	3	4
10	(250)	2	3	3	4	5
12	(300)	3	4	4	6	7
16	(400)	4	6	7	10	13

\*Based on 3.25-g available chlorine per tablet

the trench, their positions shall be marked on the pipe exterior to indicate that the pipe has been installed with the tablets at the top.

4.3.4 *Filling and contact time.* When installation has been completed, the main shall be filled with water such that the full pipe velocity is no greater than 1 ft/sec (0.3 m/sec). Fill rate must be carefully controlled to ensure tablets do not come loose from pipe. Precautions shall be taken to ensure that air pockets are eliminated. As an optional procedure, if required by the purchaser, water used to fill the new main shall be supplied through a temporary connection that shall include an appropriate cross-connection control device, consistent with the degree of hazard, for backflow protection of the active distribution system (see Figure 1).

The chlorinated water shall remain in the pipe for at least 24 hr. If the water temperature is less than 41°F (5°C), the water shall remain in the pipe for at least 48 hr. A detectable free chlorine residual ( $\geq 0.2$  mg/L) shall be found at each sampling point after the 24- or 48-hr period.

## Sec. 4.4 Continuous-Feed Method of Chlorination

4.4.1 *Continuous-feed method.* The continuous-feed method consists of completely filling the main with potable water, removing air pockets, then flushing the completed main to remove particulates, and refilling the main with potable water that has been chlorinated to 25 mg/L. After a 24-hr holding period in the main there shall be a free chlorine residual of not less than 10 mg/L.

4.4.2 *Preliminary flushing.* Before the main is chlorinated, it shall be filled with potable water to eliminate air pockets and flushed to remove particulates. The flushing velocity in the main shall not be less than 3.0 ft/sec (0.91 m/sec) unless

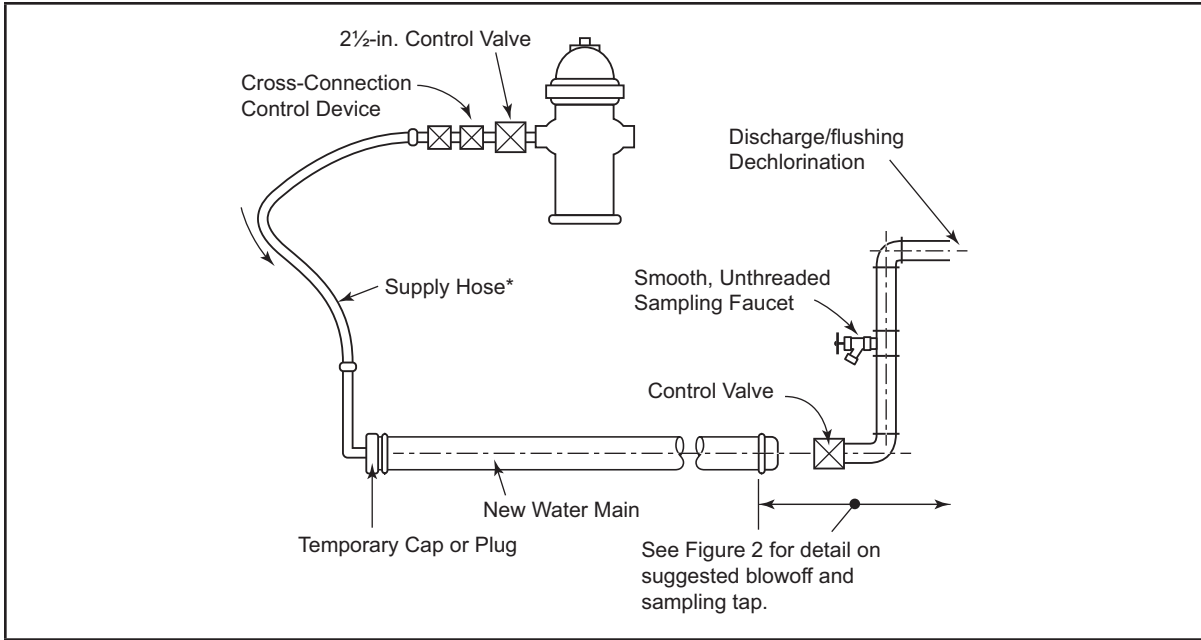

NOTE: Figure 1 applies to pipes with diameters 4 in. (100 mm) through 12 in. (300 mm). Larger sizes must be handled on a case-by-case basis.

\*Clean potable-water hose only. Size and number of taps per Table 3. This hose must be removed during the hydrostatic pressure test.

Figure 1 Suggested temporary flushing/testing connection

**Table 3 Required flow and openings (either taps or hydrants) to flush pipelines at 3.0 ft/sec (0.91 m/sec) (40 psi [276 kPa] residual pressure in water main)\***

Pipe Diameter		Flow Required to Produce 3.0 ft/sec (approx.) Velocity in Main		Size of Tap Used, in. (mm)			Number of Hydrant Outlets	
				1 (25)	1½ (38)	2 (51)		
in.	(mm)	gpm	(L/sec)	Number of Taps Required on Pipe†			2½-in. (64-mm)	4½-in. (114 mm)
4	(100)	120	(7.4)	1	—	—	1	1
6	(150)	260	(16.7)	—	1	—	1	1
8	(200)	470	(29.7)	—	2	—	1	1
10	(250)	730	(46.3)	—	3	2	1	1
12	(300)	1,060	(66.7)	—	—	3	2	1
16	(400)	1,880	(118.6)	—	—	5	2	1

\*With a 40-psi (276-kPa) pressure in the main with the hydrant flowing to atmosphere, a 2½-in. (64-mm) hydrant outlet will discharge approximately 1,000 gpm (63.1 L/sec); and a 4½-in. (114-mm) hydrant outlet will discharge approximately 2,500 gpm (160 L/sec).

†Number of taps on pipe based on 3.0-ft/sec discharge through 5 ft (1.5 m) of galvanized iron (GI) pipe with one 90° elbow.

the purchaser determines that conditions do not permit the required flow to be discharged to waste. Table 3 shows the rates of flow required to produce a velocity of 3.0 ft/sec (0.91 m/sec) in commonly used sizes of pipe. (NOTE: flushing is no substitute for preventive measures during construction. Certain contaminants, such as caked deposits, resist flushing at any feasible velocity, and pigging of the main, or other suitable method acceptable to the purchaser, may be required.) Where such flow rates are not possible, flushing at the maximum expected flow rate for the line for 2–3 volumes may be acceptable. For larger mains, pigging (or other suitable method acceptable to the purchaser) is an option in place of high velocity flushing.

For 24-in. (600-mm) or larger diameter mains, an acceptable alternative to flushing is to broom-sweep the main, carefully removing sweepings prior to filling and chlorinating the main. WARNING: OSHA requirements for confined space need to be addressed before entering a pipeline.

#### 4.4.3 Procedure for chlorinating the main.

1. Potable water may be supplied from a temporary backflow-protected connection to the existing distribution system or other supply source approved by the purchaser. The cross-connection control device shall be consistent with the degree of hazard for backflow protection of the active distribution system (see Figure 1). The flow shall be at a constant, measured rate into the newly installed water main. In the absence of a meter, the rate may be approximated using a Pitot gauge in the discharge, measuring the time to fill a container of known volume, or measuring the trajectory of the discharge and using the formula shown in Figure 2. The main should undergo hydrostatic testing prior to disinfection.

2. At a point not more than 10 ft (3 m) downstream from the beginning of the new main, water entering the new main shall receive a dose of chlorine fed at a constant rate such that the water will have not less than 25 mg/L free chlorine. To ensure that an appropriate concentration is achieved, the free chlorine concentration shall be measured at regular time intervals in accordance with the procedures described in *Standard Methods for the Examination of Water and Wastewater* or AWWA Manual M12, or using appropriate chlorine test kit (see appendix A).

Table 4 gives the amount of chlorine required for each 100 ft (30.5 m) of pipe for various pipe diameters. Solutions with a minimum 1 percent chlorine concentration may be prepared with sodium hypochlorite or calcium hypochlorite. The latter solution requires 1 lb (454 g) of calcium hypochlorite in 8 gal (30.3 L) of water.

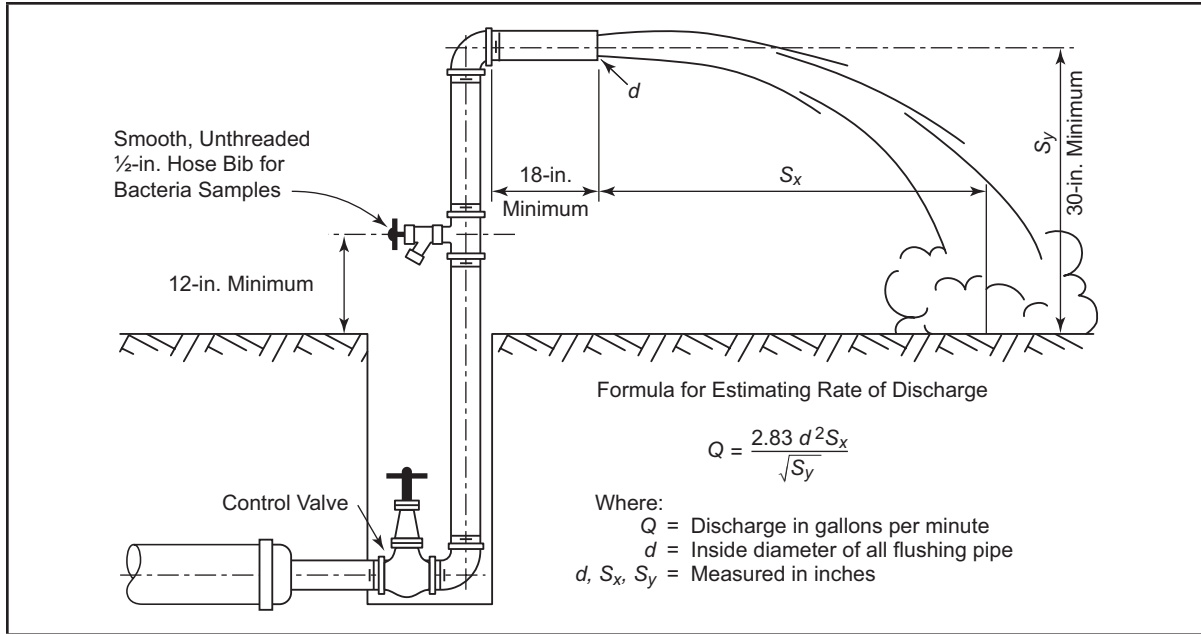

NOTE: This figure applies to pipes up to and including 8-in. (200-mm) diameter.

Figure 2 Suggested combination blowoff and sampling tap

**Table 4 Chlorine required to produce an initial 25-mg/L concentration in 100 ft (30.5 m) of pipe by diameter**

Pipe Diameter		100% Chlorine		1% Chlorine Solution	
<i>in.</i>	<i>(mm)</i>	<i>lb</i>	<i>(g)</i>	<i>gal</i>	<i>(L)</i>
4	(100)	0.013	(5.9)	0.16	(0.6)
6	(150)	0.030	(13.6)	0.36	(1.4)
8	(200)	0.054	(24.5)	0.65	(2.5)
10	(250)	0.085	(38.6)	1.02	(3.9)
12	(300)	0.120	(54.4)	1.44	(5.4)
16	(400)	0.217	(98.4)	2.60	(9.8)

3. Chlorine application shall not cease until the entire main is filled with chlorinated water. The chlorinated water shall be retained in the main for at least 24 hr, during which time valves and hydrants in the treated section shall be operated to ensure disinfection of the appurtenances. At the end of this 24-hr period, the treated water in all portions of the main shall have a residual of not less than 10 mg/L of free chlorine.

4. Direct-feed chlorinators, which operate solely from gas pressure in a chlorine cylinder, shall not be used for the application of liquid chlorine (gas). (The

danger of using direct-feed chlorinators is that water pressure in the main can exceed gas pressure in the chlorine cylinder. This allows backflow of water into the cylinder, resulting in severe cylinder corrosion and the escape of chlorine gas.)

The preferred equipment for applying liquid chlorine (gas) is a solution-feed, vacuum-operated chlorinator and a booster pump. The vacuum-operated chlorinator mixes the chlorine gas in solution water; the booster pump then injects the chlorine solution into the main to be disinfected. Hypochlorite solutions may be applied to the water main with a chemical-feed pump designed for feeding chlorine solutions. Feed lines shall be made of material capable of withstanding the corrosion caused by the concentrated chlorine solutions and the maximum pressures that may be created by the pumps. All connections shall be checked for tightness before the solution is applied to the main.

## Sec. 4.5 Slug Method of Chlorination

4.5.1 *Slug method.* The slug method consists of completely filling the main to eliminate air pockets; flushing the main to remove particulates; then slowly flowing through the main a slug of water dosed with chlorine to a concentration of 100 mg/L. The slow rate of flow ensures that all parts of the main and its appurtenances will be exposed to the highly chlorinated water for a period of not less than 3 hr.

4.5.2 *Preliminary flushing.* Same as Sec. 4.4.2.

4.5.3 *Procedure for chlorinating the main.*

1. Potable water may be supplied from a temporary backflow-protected connection to the existing distribution system or other supply source approved by the purchaser. The cross-connection control device shall be consistent with the degree of hazard for backflow protection of the active distribution system (see Figure 1). The flow shall be at a constant, measured rate into the newly installed water main. In the absence of a meter, the rate may be approximated using a Pitot gauge in the discharge, measuring the time to fill a container of known volume, or measuring the trajectory of the discharge and using the formula shown in Figure 2. The main should undergo hydrostatic testing prior to disinfection.

2. At a point not more than 10 ft (3 m) downstream from the beginning of the new main, water entering the new main shall receive a dose of chlorine fed at a constant rate such that the water will have not less than 100 mg/L free chlorine. To ensure that this concentration is achieved, the free chlorine concentration shall be measured at regular time intervals sufficient to guide the completion of the successful loading of the target chlorine concentration. The chlorine shall be applied



continuously and for a sufficient period to develop a solid column, or slug, of chlorinated water that will, as it moves through the main, expose all interior surfaces to a concentration of approximately 100 mg/L for at least 3 hr.

3. The free chlorine residual shall be measured in the slug as it moves through the main. If at any time it drops below 50 mg/L, the flow shall be stopped; chlorination equipment shall be relocated at the head of the slug; and, as flow resumes, chlorine shall be applied to restore the free chlorine in the slug to not less than 100 mg/L.

4. As chlorinated water flows past fittings and valves, related valves and hydrants shall be operated so as to disinfect appurtenances and pipe branches.

#### **Sec. 4.6 Spray Disinfection for Large Transmission Lines**

For very large transmission mains (where personnel or equipment may safely enter the pipe), spray disinfection may be an appropriate and efficient means of achieving disinfection. For this method, refer to ANSI/AWWA C652, Sec. 4.3.2 (Disinfection of Water Storage Facilities; Chlorination Method 2). In general, once pipe is cleaned, spray a 200-mg/L free chlorine solution on all surfaces. After 30 min, fill line and sample as described in Sec. 5.1.

#### **Sec. 4.7 Basic Disinfection Procedure for New Mains**

The basic disinfection procedure consists of

1. Inspecting materials to be used to ensure their integrity.
2. Preventing contaminating materials from entering the water main during storage, construction, or repair and noting potential contamination at the construction site.
3. Removing, by flushing or other means, those materials that may have entered the water main or appurtenances.
4. Preventing contamination of existing mains from cross-connection during flushing, pressure testing, and disinfection.
5. Pressure testing the water main to ensure the main meets the purchaser's allowable leakage rate. Hydrostatic pressure tests should be conducted with potable water.
6. Chlorinating and adequately documenting the process used for disinfection.
7. Flushing the chlorinated water from the main. Refer to ANSI/AWWA C655 Field Dechlorination for dechlorination procedures, if dechlorination is required.

8. Determining the bacteriological quality of water samples collected from the pipe by laboratory test after disinfection.

9. Final connecting of the newly disinfected water main to the active distribution system without sacrificing sanitary practices and conditions.

## **Sec. 4.8 Preventive and Corrective Measures During New Construction**

4.8.1 *General.* Heavy particulates generally contain bacteria and prevent even very high chlorine concentrations from contacting and killing these organisms. Therefore, the procedures of this section must be observed to ensure that a water main and its appurtenances have been thoroughly cleaned for the final disinfection by chlorination. Also, any connection of a new water main to the active distribution system before the receipt of satisfactory bacteriological samples may constitute a cross-connection. Therefore, the new main must be isolated until bacteriological tests described in Section 5 of this standard are satisfactorily completed.

4.8.2 *Keeping pipe clean and dry.* The interiors of pipes, fittings, and valves shall be protected from contamination.

4.8.2.1 *Openings.* Openings in the pipeline shall be closed with watertight plugs when pipe laying is stopped at the close of the day's work or for other reasons, such as rest breaks or meal periods. Rodent-proof plugs may be used when watertight plugs are not practicable and when thorough cleaning will be performed by flushing or other means.

4.8.2.2 *Stringing pipe.* Pipe delivered for construction shall be strung to minimize the entrance of foreign material.

4.8.2.3 *Delays.* Delay in placement of delivered pipe invites contamination. The more closely the rate of delivery is correlated to the rate of pipe laying, the lower the risk of contamination.

4.8.3 *Joints.* Joints of pipe in the trench shall be completed before work is stopped. If water accumulates in the trench, the plugs shall remain in place until the trench is free of standing water and mud that may enter the pipe.

4.8.4 *Packing materials.* Yarning or packing material shall consist of molded or tubular rubber rings, rope of treated paper, or other approved materials. Materials such as jute or hemp shall not be used. Packing material shall be handled in a manner that avoids contamination.

4.8.5 *Sealing materials.* No contaminated material or any material capable of supporting growth of microorganisms shall be used for sealing joints. Sealing material or gaskets shall be handled in a manner that avoids contamination. The lubricant used in the installation of sealing gaskets shall be suitable for use in

potable water meeting the requirements of NSF/ANSI 61 and shall not contribute odors. It shall be delivered to the job in closed containers and shall be kept clean and applied with dedicated clean applicators.

4.8.6 *Cleaning and swabbing.* If dirt enters the pipe, it shall be removed and the interior pipe surface swabbed with a minimum 1 percent free chlorine disinfecting solution. If, in the opinion of the purchaser, the dirt remaining in the pipe will not be removed using the flushing operation, the interior of the pipe shall be cleaned using mechanical means, such as a hydraulically propelled foam pig (or other suitable device acceptable to the purchaser) in conjunction with the application of a minimum 1 percent free chlorine disinfecting solution. The cleaning method used shall not force mud or debris into the interior pipe-joint spaces and shall be acceptable to the purchaser.

4.8.7 *Wet-trench construction.* If it is not possible to keep the pipe and fittings dry during installation, a scour flush at 3.0 ft/sec (0.91 m/sec) or greater for a minimum of three pipe volumes (see Table 3) followed by slug or continuous-feed chlorination and bacteria testing before release is required. For larger mains, pigging or other suitable method acceptable to the purchaser is an option in place of high-velocity flushing.

4.8.8 *Flooding by storm or accident during construction.* If the main is flooded during construction, it shall be cleared of the floodwater by draining and flushing with potable water until the main is clean. The section exposed to the floodwater shall then be filled with a chlorinated potable water that, at the end of a 24-hr holding period, will have a free chlorine residual of not less than 25 mg/L. The chlorinated water may then be drained or flushed from the main. If chemical contamination occurs, such as a hydraulic oil leak or petroleum product spill, the pipe sections exposed to the contamination should be replaced and not reused for potable water applications. After construction is completed, the main shall be disinfected using the continuous-feed, slug, or spray methods.

4.8.9 *Backflow protection (optional).*\* As an optional procedure (if required by the purchaser), the new water main shall be kept isolated from the active distribution system using a physical separation (see Figure 1) until satisfactory bacteriological testing has been completed and the disinfection water flushed out.

Water required to fill the new main for hydrostatic pressure testing, disinfection, and flushing shall be supplied through a temporary connection between the

---

\* Optional Sec. 4.8.9 is not included as part of the standard unless required by the purchaser.

distribution system and the new main or other supply source approved by the purchaser. The temporary connection shall include an appropriate cross-connection control device consistent with the degree of hazard (a double check valve assembly or a reduced pressure zone assembly) and shall be disconnected (physically separated) from the new main during the hydrostatic pressure test. It will be necessary to reestablish the temporary connection after completion of the hydrostatic pressure test to flush out the disinfectant water prior to final connection of the new main to the distribution system. NOTE: Exposure to high levels of chlorine or high pH can cause severe irritation to customers. Also, the chlorinated water can be high in disinfection by-products.

## **Sec. 4.9 Final Flushing for New Mains**

4.9.1 *Clearing the main of heavily chlorinated water.* After the applicable retention period, heavily chlorinated water should not remain in prolonged contact with pipe. In order to prevent damage to the pipe lining or to prevent corrosion damage to the pipe itself, the heavily chlorinated water shall be flushed from the main fittings, valves, and branches until chlorine measurements show that the concentration in the water leaving the main is no higher than that generally prevailing in the distribution system or that is acceptable for domestic use.

4.9.2 *Disposing of heavily chlorinated water.* The environment to which the chlorinated water is to be discharged shall be inspected. If there is any possibility that the chlorinated discharge will cause damage to the environment, a neutralizing chemical shall be applied to the water to be wasted to thoroughly neutralize the residual chlorine (see ANSI/AWWA C655 for neutralizing chemicals). Where necessary, federal, state, local, or provincial regulatory agencies should be contacted to determine special provisions for the disposal of heavily chlorinated water.

## **Sec. 4.10 Final Connections to Existing Mains**

Water mains and appurtenances must be completely installed, flushed, disinfected, and satisfactory bacteriological sample results received prior to permanent connections being made to the active distribution system. Sanitary construction practices must be followed during installation of the final connection so that there is no contamination of the new or existing water main with foreign material or groundwater.

4.10.1 *Connections equal to or less than one pipe length (generally  $\leq 20$  ft [ $6$  m]).* The new pipe, fittings, and valve(s) required for the connection may be spray disinfected or swabbed with a minimum 1 percent solution of chlorine just

before being installed, if the total length of the connection from the end of a new main to the existing main is equal to or less than 20 ft (6 m).

4.10.2 *Connections greater than one pipe length (generally >20 ft [6 m]).* The pipe required for the connection must be set up aboveground, disinfected, and bacteriological samples taken, as described in Section 5, if the total length of the connection from the end of a new main to the existing main is greater than 20 ft (6 m). After satisfactory bacteriological sample results have been received for the predisinfected pipe, the pipe can be used in connecting the new main to the active distribution system. Between the time the satisfactory bacteriological sample results are received and the time that the connection piping is installed, the ends of the piping must be sealed with plastic wraps, watertight plugs, or caps.

### **Sec. 4.11 Disinfection Procedures When Cutting Into or Repairing Existing Pipe**

4.11.1 *General.* The planned, unplanned, or emergency repair of a water main or appurtenance (e.g., valve) is time sensitive—an important goal is to minimize the disruption of water service to customers. Nonetheless, the repair work needs to be accomplished using sanitary and safe procedures by well-trained crews with proper supervision and guidance. Refer to preventive and corrective measures described previously in Sec. 4.8.2, 4.8.3, 4.8.4, and 4.8.5. Follow all personal protection precautions when working with chlorine solutions.

4.11.2 *Basic disinfection.* Work should follow basic disinfection and contamination prevention procedures:

1. Preventing contaminants from entering the existing pipe during the repair such as by maintaining positive pressure in the leaking pipe until the repair site on the pipe is fully exposed, by maintaining a dewatered trench, and by keeping all pipe materials being used in the repair in a clean and sanitary condition.

2. Inspecting and cleaning, followed by disinfection of spraying or swabbing with a minimum 1 percent chlorine solution:

- Exposed portions of existing pipe interior surfaces
- Pipe materials used in the repair
- Handheld materials and tools used to make the repair

3. As appropriate, advising affected customers to adequately flush their service lines upon return to service.

4.11.3 *Selection of disinfection procedure.* The disinfection procedure selected should be determined by the conditions and severity of the main break. Many leaks or breaks can be repaired under controlled conditions without depressurizing the water main, such as when applying a clamp to a small crack or hole,

thus preventing contaminants from entering the water system. In most other situations, the water main can be maintained pressurized until the break site is secured and the pipe is fully exposed. Some circumstances (e.g., severe erosion of the local environment or icing of the roadway) that impact public safety may require that water pressure be substantially reduced prior to exposing the pipe in the area of the leak. In some cases, situations become catastrophic where there is a pipe blow-out and a loss of water pressure prior to shutdown, requiring disinfection procedures equivalent to those of a new main installation. The procedures described in Sec. 4.11.3.1 through 4.11.3.3 describe the contamination risks and the associated disinfection and sampling requirements for different scenarios of pipeline repair. Specific situations not captured below need to be evaluated and the appropriate disinfection and sampling methods followed.

Note that the procedures explained in Sec. 4.11.3.1, 4.11.3.2, and 4.11.3.3 for distribution mains may need to be modified for large transmission mains. Large mains may need additional work (such as having a valve replaced or requiring a special order on a connection), may be out of service for more than a day, or may not be able to accommodate a scour flush. These modifications need to be made on a case-by-case basis but should still take into account the procedures outlined in ANSI/AWWA C651.

**4.11.3.1 Controlled pipe repair without depressurization.** In this situation, activities are well controlled and a full shutdown is not needed, thus maintaining positive pressure to the area of shutdown and around the break site at all times. The repair site is exposed and the trench is adequately dewatered so that the repair site can be cleaned and disinfected by spraying or swabbing with a minimum 1 percent chlorine solution. The water main is then returned to service with flushing to obtain three volumes of water turnover, making sure that the flushed water is visually clear. No bacteriological testing is necessary. It is advisable to check for a typical system chlorine residual, and if not found, to continue flushing until residuals are restored to levels maintained in the distribution system by the water utility—if the system operates with a disinfectant residual.

**4.11.3.2 Controlled pipe repair with depressurization after shutdown.** In this situation, after the repair site has been exposed and secured from trench soil/water contamination, the water main is depressurized by a shutdown to complete the repair. The repair site should be cleaned and disinfected by spraying or swabbing with a minimum 1 percent chlorine solution. The water main is then returned to service with flushing to scour the pipe and obtain three volumes of water turn-

over, making sure that the flushed water is visually clear. It is advisable to check for a typical system chlorine residual, and if not found, to continue flushing until residuals are restored to levels maintained in the distribution system by the water utility—if the system operates with a disinfectant residual.

When the existing pipe has to be opened and the interior surfaces of the water system exposed to the environment, additional procedures need to be followed. The existing pipe should be inspected and cleaned with the help of flushing water into the trench, where possible, until the flush water runs visually clear. The repair site should be accessible and the trench adequately dewatered so that the repair site can be cleaned and disinfected by spraying or swabbing with a minimum 1 percent chlorine solution. Additionally, any accessible upstream and downstream interior of the existing pipe should be disinfected by swabbing or spraying with a minimum 1 percent chlorine solution. If the repair requires a full pipe section replacement, the new pipe should be inspected, cleaned, and disinfected from both ends by swabbing with a minimum 1 percent chlorine solution. The water main may then be returned to service after flushing to scour the pipe and obtain three volumes of water turnover. The flushed water should run visually clear, have a measurable chlorine residual if the system operates with a residual, and be checked with bacteriological testing. The pipeline may be returned to service prior to obtaining bacteriological results.

4.11.3.3 Uncontrolled pipe break with a likelihood of water contamination or loss of sanitary conditions during repair. In situations in which the existing main to be repaired could not be protected and kept free of contamination and there are obvious signs of contamination (e.g., muddy trench water flowing into the broken pipe and a leaking sewer pipe in the trench, or catastrophic pipe failure where pipe is open and there is a likelihood that contamination was drawn into the active system) or when a controlled repair situation turns into a situation in which the internal pipe and water have become contaminated, the procedures outlined in Sec. 4.3, 4.4, 4.5, or 4.6 should be followed where practical. These methods specify chlorine doses of 25–300 mg/L; however, such levels may present greater harm if the line or services cannot be reliably isolated or shut down and exposure of customers to high concentrations of chlorine cannot be controlled. Free chlorine residuals up to 4 mg/L (based on annual averages) are allowed by federal drinking water regulations; therefore this level is suggested as a minimum to be maintained for at least 16 hr in conjunction with flushing, coliform sampling, and associated customer education. Such situations require careful review and need to balance the public health risks of the pipeline failure as well as the repair process.

Where practical and appropriate considering the risks of public exposure to high concentrations of chlorine, in addition to the procedures previously described in this standard, the section of pipe in which the break is located shall be isolated, all service connections shut off, and the section flushed and disinfected. If the slug chlorination method is employed, the dose may be increased to as much as 300 mg/L and the contact time reduced to as little as 15 min. After chlorination and repair, perform scour flushing at 3.0 ft/sec (0.91 m/sec) or greater for a minimum of three pipe volumes and continue until discolored water is not observed and the chlorine residual is restored to the levels maintained in the distribution system by the water utility.

For larger-diameter pipe (12 in. and greater), if a water velocity of 3.0 ft/sec (0.91 m/sec) cannot be achieved, it is desirable to flush at the maximum flow for the main until three pipe volumes have been displaced before returning the main to service. The flushed water should run visually clear, and have typical system chlorine residual (if the system operates with a disinfectant residual).

For very-large-diameter pipe (where personnel may safely enter the pipe), in lieu of flushing following disinfection, the interior of the pipe at the repair site may be cleaned by sweeping or high pressure wash using potable water before disinfection. Standing water and debris from the cleaning must be removed from the pipe prior to disinfection. The affected pipe shall be disinfected by swabbing or spraying with a minimum 1 percent chlorine solution.

After following the appropriate methods above, prior to returning the pipe to service, the efficacy of the disinfection procedure shall be verified by testing for the absence of coliform bacteria. If allowed by local regulations, the pipeline may be returned to limited service prior to obtaining bacteriological results with proper notification of the affected customers.

**4.11.4 Temporary service lines.** Temporary water service lines to customers during main repair activities shall be disinfected prior to use. Materials shall meet the NSF/ANSI 61 certification for potable water use. Disinfection should be accomplished by the procedures in Sec. 4.4 or 4.5 followed by scour flushing at 3.0 ft/sec (0.91 m/sec) or greater for a minimum of three pipe volumes (see Table 3), or until the water runs visually clear and preferably a measurable chlorine residual is restored.



---

## SECTION 5: VERIFICATION

---

### Sec. 5.1 Bacteriological Tests

5.1.1 *Standard conditions for new mains.* It should be recognized that the primary means of ensuring the sanitary integrity of a main are the sanitary handling of materials, the practices during construction, and continual inspection of work. After disinfection and final flushing such that typical system chlorine residuals are present, if the system operates with a residual, samples shall be collected as follows:

5.1.1.1 For new mains, the purchaser has two options for the bacteriological testing for total coliform analysis.

Option A: Before approving a main for release, take an initial set of samples and then resample again after a minimum of 16 hr using the sampling site procedures outlined. Both sets of samples must pass for the main to be approved for release.

Option B: Before approving a main for release, let it sit for a minimum of 16 hr without any water use. Then collect, using the sampling site procedures outlined and without flushing the main, two sets of samples a minimum of 15 min apart while the sampling taps are left running. Both sets of samples must pass for the main to be approved for release.

A set of samples includes all samples collected along the length of the pipeline, as described in Sec. 5.1.1.2.

5.1.1.2 For new mains, sets of samples shall be collected every 1,200 ft (370 m) of the new water main, plus one set from the end of the line and at least one from each branch greater than one pipe length.

5.1.1.3 If trench water has entered the new main during construction or if, in the opinion of the purchaser, excessive quantities of dirt or debris have entered the new main, bacteriological samples shall be taken at intervals of approximately 200 ft (61 m), and the sampling location shall be identified (see Sec. 5.1.3 for sampling location details). Samples shall be taken of water that has stood in the new main for at least 16 hr after final flushing has been completed.

5.1.1.4 A standard heterotrophic plate count (HPC) test may be required at the option of the purchaser because new mains do not typically contain coliform bacteria but often contain HPC bacteria. If sample results show HPC greater than 500 CFU/mL, flushing should resume and another set of HPC and coliform samples collected until no coliform are present and the HPC is less than 500 CFU/mL.

5.1.2 *Standard conditions for repaired mains.* It should be recognized that the primary means of ensuring the sanitary integrity of a main are the sanitary handling of materials, the practices during repair work, and continual inspection of work. After disinfection and final flushing, samples shall be collected as follows:

5.1.2.1 For repaired mains that were depressurized and/or wholly or partially dewatered, one set of samples may be required, and depending upon the sanitary conditions, the line may be reactivated prior to the completion of bacteriological testing. Samples shall be collected downstream of the repair site and at intervals of approximately 200 ft (61 m) within the length of pipe that was shut down. If direction of flow is not known, samples shall be collected on either side of the repair site. Refer to Sec. 4.11.

5.1.2.2 For repaired mains that were maintained under pressurized conditions at all times, disinfection and/or testing may not be required. Refer to Sec. 4.11.3.

5.1.2.3 However, under either main repair scenario, it is advisable where possible to provide a scour flush to clear before the release of the repaired section.

5.1.3 *Sampling procedure.* Samples for bacteriological analysis shall be collected in sterile bottles treated with sodium thiosulfate, in accordance with Section 9060—Samples of *Standard Methods for the Examination of Water and Wastewater*. Hoses and fire hydrants are not recommended for the collection of samples that will be used to make decisions on the bacteriological quality of drinking water. However, if no sampling port is available, cleaned fire hydrants that have been cleared of standing water and/or other sanitized sampling apparatus (i.e., sanitized tubing, hose, gooseneck, spigot) may be used with the understanding that they do not represent optimum access to the water main for bacteriological sampling. A suggested combination blowoff and sampling tap used for mains up to and including 8-in. (200-mm) diameter is shown in Figure 2. There should be no water in the trench up to the connection for sampling. The sampling pipe must be dedicated and clean and disinfected and flushed prior to sampling. A corporation cock may be installed in the main with a copper-tube gooseneck assembly. After samples have been collected, the gooseneck assembly may be removed and retained for future use and the corporation cock should be capped or taped for future reuse. If corporation cocks are placed at the 12 o'clock position, they may be struck more easily during future excavations.

5.1.4 *Sample results.* Samples shall be tested for bacteriological quality in accordance with *Standard Methods for the Examination of Water and Wastewater* and shall show the absence of coliform bacteria.

In addition, it is recommended that samples be tested for acceptable aesthetic quality (e.g., chlorine residual, pH, alkalinity, specific conductance, turbidity). Levels should be as expected or typical for the water system. For new mains, a standard heterotrophic plate count test may be required at the option of the purchaser because new mains do not typically contain coliform bacteria but often contain HPC bacteria. If sample results show HPC greater than 500 CFU/mL, flushing should resume and another set of HPC and coliform samples collected until no coliform are present and the HPC is less than 500 CFU/mL.

5.1.5 *Record of compliance.* The record of compliance shall be the bacteriological test results certifying that the water sampled is free of coliform bacteria contamination.

5.1.6 *Redisinfection.* If the initial disinfection fails to produce satisfactory bacteriological results, or if other results indicate unacceptable water quality, the main may be reflushed and shall be resampled. If check samples fail to produce acceptable results, the main shall be rechlorinated by the continuous-feed or slug method until satisfactory results are obtained—that being acceptable samples taken as described in Sec. 5.1.1.1.

NOTE: In the case of new mains, high velocities in the adjacent existing system, resulting from flushing the new main, may disturb sediment that has accumulated in the existing mains. When check samples are taken, it is advisable to sample water entering the new main to determine if excessive turbidity is present that could be interfering with results.

## Sec. 5.2 Optional Sampling and Testing

If a pipeline is not promptly returned to service, the situation should be evaluated to determine if the water quality may have been impacted and if additional testing is warranted. Test results should confirm that the water quality is appropriate for distribution. Although this assessment is unique for each system, parameters considered for testing include disinfectant residual, total coliform bacteria, HPC, turbidity, pH, alkalinity, total chlorine, odor, and specific conductance.

---

## SECTION 6: DELIVERY

---

This standard has no applicable information for this section.

This page intentionally blank.

# APPENDIX A

## Chlorine Residual Testing

*This appendix is for information only and is not a part of ANSI/AWWA C651.*

---

### SECTION A.1: DPD DROP DILUTION METHOD (FOR FIELD TEST)

---

The N, N-diethyl-p-phenylenediamine (DPD) drop dilution method of approximating total residual chlorine is suitable for concentrations above 10 mg/L, such as those applied in the disinfection of water mains or tanks.

#### Sec. A.1.1 Apparatus

1. A graduated cylinder for measuring distilled water.
2. An automatic or safety pipette.
3. Two dropping pipettes that deliver a 1-mL sample in 20 drops. One pipette is for dispensing the water sample, and the other is for dispensing the DPD and buffer solutions. The pipettes should not be interchanged.
4. A comparator kit containing a suitable range of standards.

#### Sec. A.1.2 Reagents

1. DPD indicator solution. Prepare as prescribed in *Standard Methods for the Examination of Water and Wastewater*.

#### Sec. A.1.3 Procedure

1. Add 10 drops of DPD solution and 10 drops of buffer solution (or 20 drops of combined DPD-buffer solution) to a comparator cell.
2. Fill the comparator cell to the 10-mL mark with distilled water.
3. With a dropping pipette, add the water sample one drop at a time; mix until a red color is formed that matches one of the color standards.
4. Record the total number of drops used and the final chlorine reading obtained (that is, the chlorine reading of the matched standard).
5. Calculate the milligrams per liter of free residual chlorine as follows:

$$\text{mg/L chlorine} = \frac{\text{reading} \times 200}{\text{drops of sample}}$$

---

## SECTION A.2: HIGH-RANGE CHLORINE TEST KITS

---

Several manufacturers produce high-range chlorine test kits that are inexpensive, easy to use, and satisfactory for the precision required.

# APPENDIX B

## Chlorine Dosages

*This appendix is for information only and is not a part of ANSI/AWWA C651.*

**Table B.1 Amounts of chemicals required to produce various chlorine concentrations in 100,000 gal (378.5 m<sup>3</sup>) of water\***

Desired Chlorine Concentration in Water <i>mg/L</i>	Liquid Chlorine Required <i>lb (kg)</i>		Sodium Hypochlorite Required						Calcium Hypochlorite Required	
			5% Available Chlorine		10% Available Chlorine		15% Available Chlorine		65% Available Chlorine	
			<i>gal</i>	<i>(L)</i>	<i>gal</i>	<i>(L)</i>	<i>gal</i>	<i>(L)</i>	<i>lb</i>	<i>(kg)</i>
2	1.7	(0.77)	3.9	(14.7)	2.0	(7.6)	1.3	(4.9)	2.6	(1.18)
10	8.3	(3.76)	19.4	(73.4)	9.9	(37.5)	6.7	(25.4)	12.8	(5.81)
50	42.0	(19.05)	97.0	(367.2)	49.6	(187.8)	33.4	(126.4)	64.0	(29.03)

\*Amounts of sodium hypochlorite are based on concentrations of available chlorine by volume. For either sodium hypochlorite or calcium hypochlorite, extended or improper storage of chemicals may have caused a loss of available chlorine.

**Table B.2 Amounts of chemicals required to produce chlorine concentration of 200 mg/L in various volumes of water\***

Volume of Water		Liquid Chlorine Required		Sodium Hypochlorite Required						Calcium Hypochlorite Required	
				5% Available Chlorine		10% Available Chlorine		15% Available Chlorine		65% Available Chlorine	
				<i>gal</i>	<i>L</i>	<i>gal</i>	<i>(L)</i>	<i>gal</i>	<i>(L)</i>	<i>gal</i>	<i>(L)</i>
10	(37.9)	0.02	(9.1)	0.04	(0.15)	0.02	(0.08)	0.02	(0.08)	0.03	(13.6)
50	(189.3)	0.10	(45.4)	0.20	(0.76)	0.10	(0.38)	0.07	(0.26)	0.15	(68.0)
100	(378.5)	0.20	(90.7)	0.40	(1.51)	0.20	(0.76)	0.15	(0.57)	0.30	(136.1)
200	(757.1)	0.40	(181.4)	0.80	(3.03)	0.40	(1.51)	0.30	(1.14)	0.60	(272.2)

\*Amounts of sodium hypochlorite are based on concentrations of available chlorine by volume. For either sodium hypochlorite or calcium hypochlorite, extended or improper storage of chemicals may have caused a loss of available chlorine.



## American Water Works Association

6666 West Quincy Avenue  
Denver, CO 80235-3098  
T 800.926.7337  
[www.awwa.org](http://www.awwa.org)



*Dedicated to the world's most important resource, AWWA sets the standard for water knowledge, management, and informed public policy. AWWA members provide solutions to improve public health, protect the environment, strengthen the economy, and enhance our quality of life.*

1P-2M 43651-2015 (01/15) IW



Printed on Recycled Paper

ISBN 978-1-62576-046-3



9 781625 760463